



ENGINEERED DURABILITY. INNOVATIVE DESIGN.



Two-part construction of high strength engineered polymers:

Replaceable Sector Neck:
high abrasion resistant polyurethane resins

Sector Frame:
glass-filled or unfilled polypropylene resins

It's Time You Checked Out Why DPI Sectors Take The Cake

- X More Durable**
- X Abrasion Resistance**
- X Lighter Weight**
- X OEM & Aftermarket**
- X Lower Factory Cost**

With hundreds of proven installations in disc filtering equipment, Diversified Plastics, Inc. is your go-to source for dependable, rugged and long lasting Sectors for your mining operation. Talk to us about your specific needs for internal or external flow characteristics, non-sticking additives, quick neck swap-outs, innovative custom capabilities and reduced lead times to meet your scheduling requirements.

Sectors From DPI:

Superior Products To Meet Your Requirements And Exceed Your Expectations

When you procure your disc filter Sectors from Diversified Plastics, Inc. you are getting innovation. The Mining Industry has recognized these Sectors for their durability, performance and economic advantage.

“DPI’s Sectors outlast and outperform the competition in wear and durability.”

Chris Rasch, B&R Engineering

Let’s look at the DPI difference:

- DPI Sectors are available for both OEM and aftermarket applications and come in a variety of sizes
- Because most Sector wear occurs in the necks where the majority of torque is applied, DPI Sector necks are easily removable and replaceable during routine maintenance or unexpected downtime
- DPI Sectors are interchangeable with most common disc filter sizes and most bag sizes
- DPI Sectors have smooth edges to extend bag wear and can be made with non-stick polymer additives to minimize internal cake buildup
- Lighter weight DPI Sectors save on shipping and are easier to handle for installation and periodic maintenance including replacement



Thousands of DPI Sectors have been subjected to the most stringent field testing and are proven in use in many mining operations. Let us work with you on your disc filter standard or custom Sector needs. You’ll find our service is as responsive as our products are durable.

Internal Flow
External Flow

Part Name	Sector Angle (θ°)	Overall Height (H)	Sector Width (W)	Neck O.D.	Sector-Rim Thickness (T)
IF 8x10-N1	36°	40-1/2"	31-7/8"	4"	2-3/16"
IF 9x10-N1	36°	42-1/2"	32-25/32"	4"	2-3/16"
EF 8x10-N6	36°	40-1/2"	31-25/32"	4-1/32"	1-3/8"
EF 2.7M-N6	36°	40-1/2"	31-25/32"	4-1/32"	1-3/8"
EF 3.2Mx10-N2	36°	51"	37-7/8"	3-5/8"	1-3/4"
EF 3.2Mx10-N4	36°	51"	37-7/8"	3-3/4"	1-3/4"
EF 3.8Mx12-N3	30°	61-11/16"	38-1/4"	3-5/8"	1-21/32"

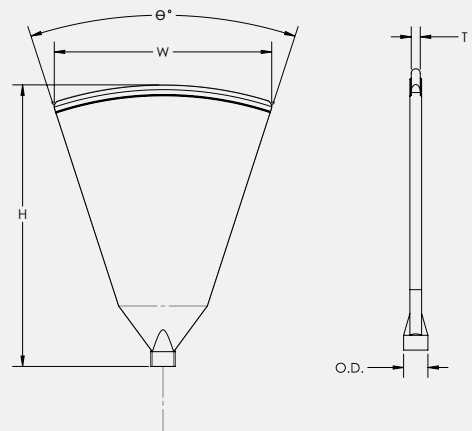

DPI has the capability of manufacturing a variety of custom sizes.

It’s time you found out more. Contact us.



We Put Polymers To Work For You.
Get A Quote On Your Project Today!
Call 800-321-0084 Or Visit
www.diversifiedplastics.net